

GROWONIX

TUNED FOR GROWING

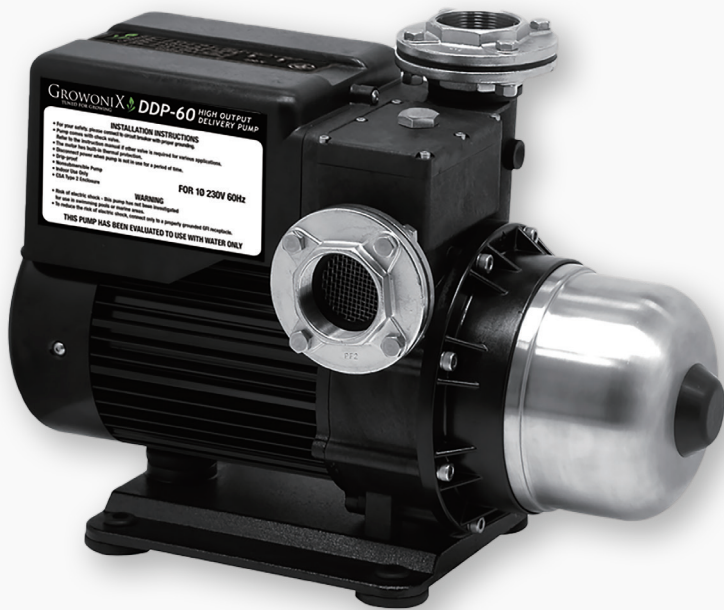

DDP-60

ELECTRONICALLY
CONTROLLED WATER
DELIVERY PUMP

WWW.GROWONIX.COM



GROWONIX
TUNED FOR GROWING



Built in the U.S.A.

INTRODUCTION

OUR MISSION

Durability, Reliability, Efficiency, Purity, and Conservation form the foundation on which we design and build all of our products. Consistent and superior quality sets us apart from other manufacturers and increases our value to you - our customer. Whether you are a hydroponics hobbyist, serious enthusiast, or large-scale gardener, GrowoniX is committed to bringing you the best solution for water purification systems.

WHAT IS REVERSE OSMOSIS?

Reverse osmosis (RO) is a filtration method that removes many types of large molecules and ions from solutions by applying pressure to the solution when it is on one side of a selective membrane. This filtering process ensures that the solute (waste water) is contained within the pressurized chamber while the pure solvent (RO water) is allowed to pass freely through the membrane.

TUNED FOR GROWING - IN TUNE WITH OUR CUSTOMERS

Traditional RO systems have waste ratios of approximately 4:1, which means there are 4 gallons of waste water produced for every 1 gallon of purified water. GrowoniX line of water filters achieve waste ratios of 2:1 with all 200-400 GPD systems, and an astounding 1:1 ratio with the 600-1000 GPD systems.

GrowoniX has created a complete product line that will address the needs of hydroponic operations of all sizes. Our filters will significantly reduce your water use while dramatically increasing your yields.

THE TRADITIONAL WAY
takes 4 gallons of waste water to produce 1 gallon of pure water

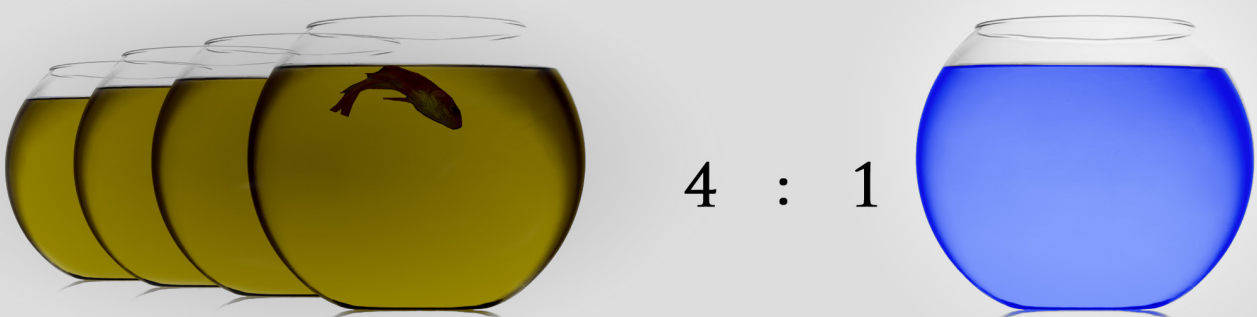

THE GROWONIX WAY



- 🌿 60 GPM water flow rate
- 🌿 Stack multiples for added Flow Rate
- 🌿 Auto Shut-Off Circuitry under 0.7GPM..
- 🌿 High pressure cutoff.
- 🌿 Ultra quiet and compact.
- 🌿 Perfect for big water transfer.
- 🌿 Perfect booster for CX Series RO systems.
- 🌿 Constant duty.

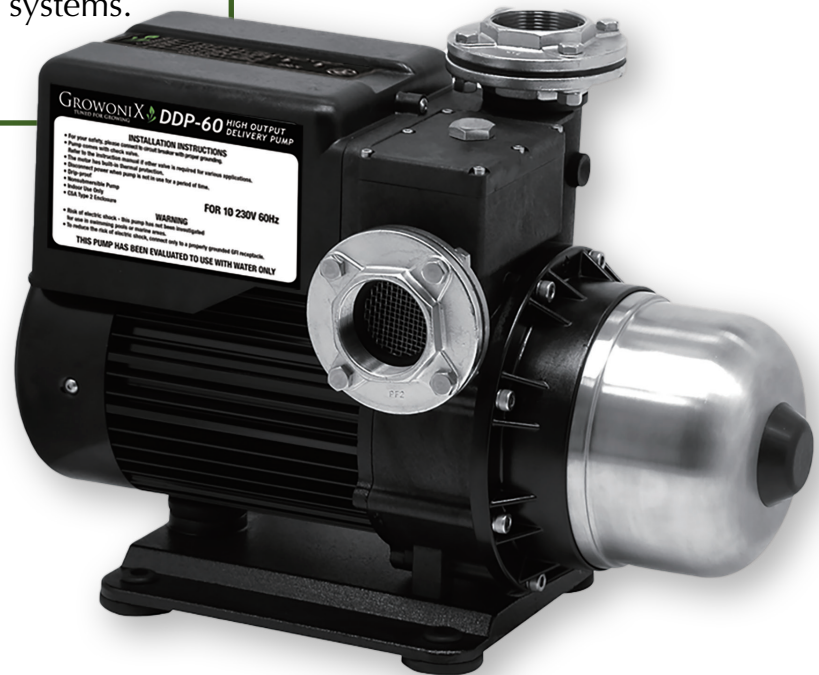

WHY USE A GROWONIX DDP-60?

- To raise the water pressure on a water filtration system.
- To transfer water from tank to tank.
- To raise the pressure on any water appliance that flows from between 5-60 GPM @ 55psi.
- To supply a faucet, shower, or hose bib.
- To pressure boost an entire house or complex plumbing system.

CONNECT MULTIPLE IN PARALLEL AND DOUBLE THE FLOW RATE!

INSTRUCTIONS

Please read all instructions carefully before installing your new DDP-60, as failures caused by incorrect installation or operation are not covered by the warranty.

I. PRODUCT

The DDP-60 is designed for the pumping of non-aggressive water, or water not containing solid particles.

II. OPERATING CONDITIONS:

1. Ambient temp: Max. +104°F (40°C)
2. Liquid temp: +39°F(4°C)~+104°F(40°C) Max.
3. System pressure: Max. 120 PSI
4. Relative humidity: Max. 85%(RH)

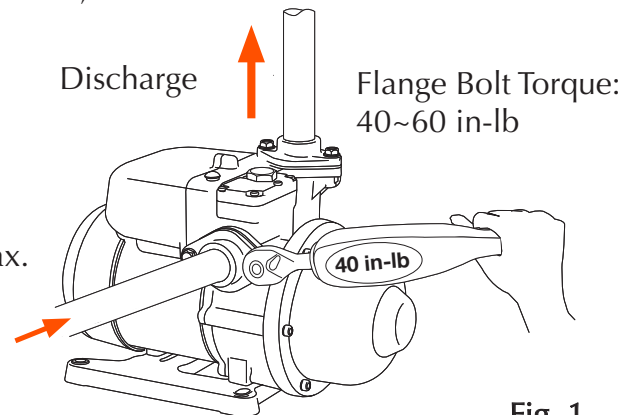

Fig. 1

III. INSTALLATION

1. The pump foundation should be rigid enough to absorb any vibration from the motor, and the pump should be securely bolted to the foundation.
2. It is recommended that the installer provides an adequate draining system to avoid damage in case of leakage, particularly when installed indoors. When it is installed outside, it should be covered by a weather-proof housing, well ventilated to allow motor heat to escape.
3. Connect the suction pipe to the side and discharge pipe on the top. (See Fig 1)
4. When it is installed with water heater, a check valve should be installed between pump (discharge) pipeline and water heater (suction) to avoid high-pressure steam backflow.
5. It is required to shut off the pump when the liquid source is unavailable; although it has the dry run cut off function.
6. Please cut out the center of the rubber gasket inside the inlet and outlet flanges as it will block the water flow. (See Fig 2)
7. Regular maintenance requires to open the prime cover in order to access the check valve.

DO NOT apply any bonded material (such as silicon, glue etc) to seal the chamber cover (See Fig 3).

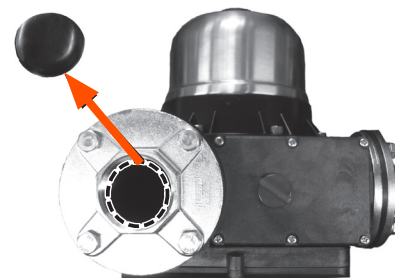

Fig. 2

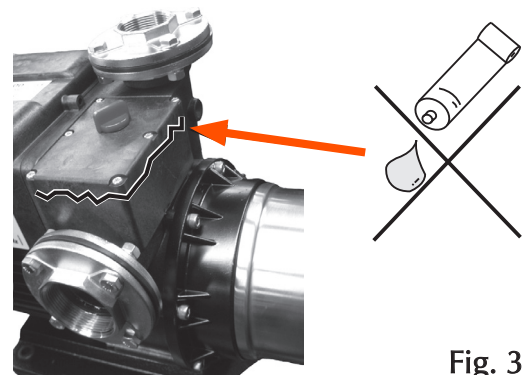

Fig. 3

IV. PIPING

1. The suction line should be installed as short and straight as possible, with a minimum of bends.
The internal diameter of the suction pipe must be equal to, or greater than the ports of the pump.
2. The connection between the suction line and pump must be airtight, and the suction pipe must be positioned so it has an upward slope to the pump (thus avoiding the formation of air pockets).
3. If it is likely the water supply may contain solid particles, such as leaves and sand, a filter should be installed on the suction line.
4. If hose is used as the suction pipe, it must be non-collapsible.
5. To minimize pressure drop, the discharge pipe should be at least the same size as the discharge port of the pump.
6. For long suction pipes or high suction lifts over 13 ft, the suction pipe should be of greater diameter than the suction port.
7. Ensure all connections are completely sealed using thread tape only.

V. CONNECTIONS TO WATER SOURCE

1. FLOODED SUCTION- FROM WELL SYSTEM

With gravity feed to the pump, there are no special adjustments to be made.

See Fig. 4 below for recommended layout. Simply make necessary plumbing connections and apply power.

The pump is ready to use.

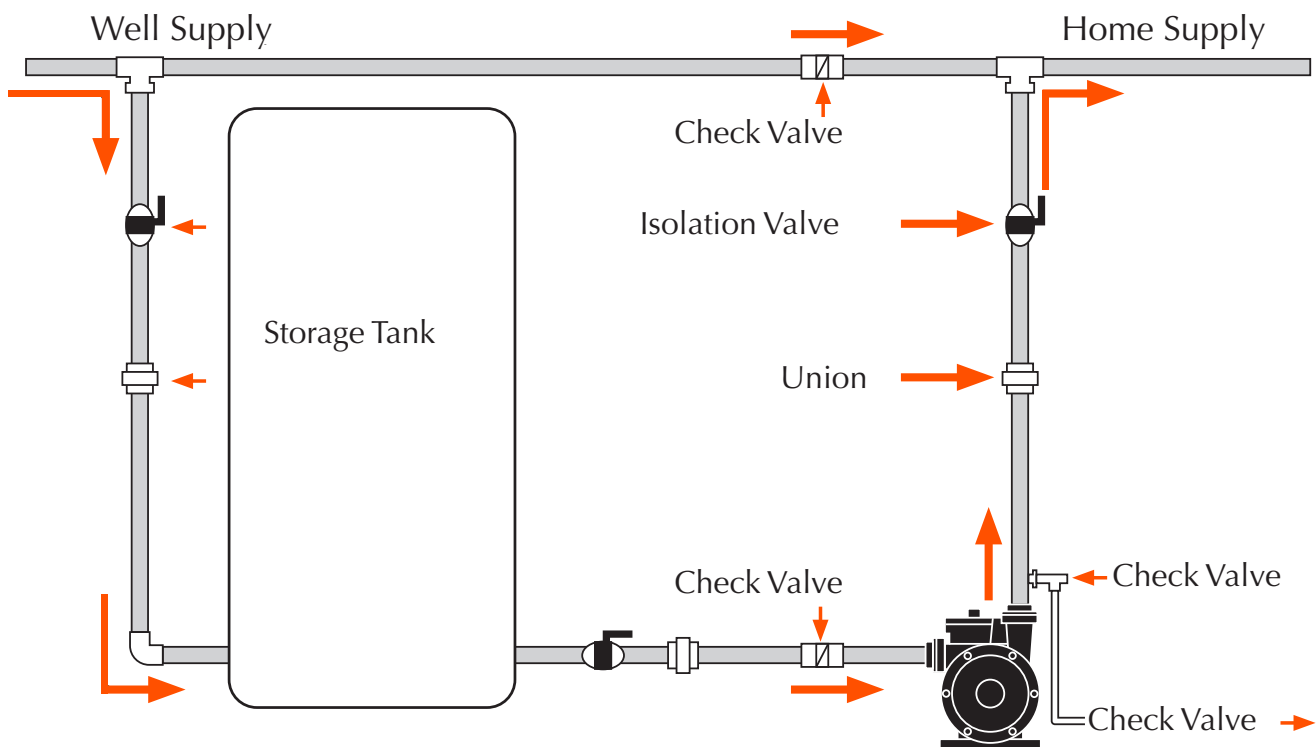

Fig. 4

INSTRUCTIONS CONT.

1. FLOODED SUCTION- FROM CITY WATER SUPPLY

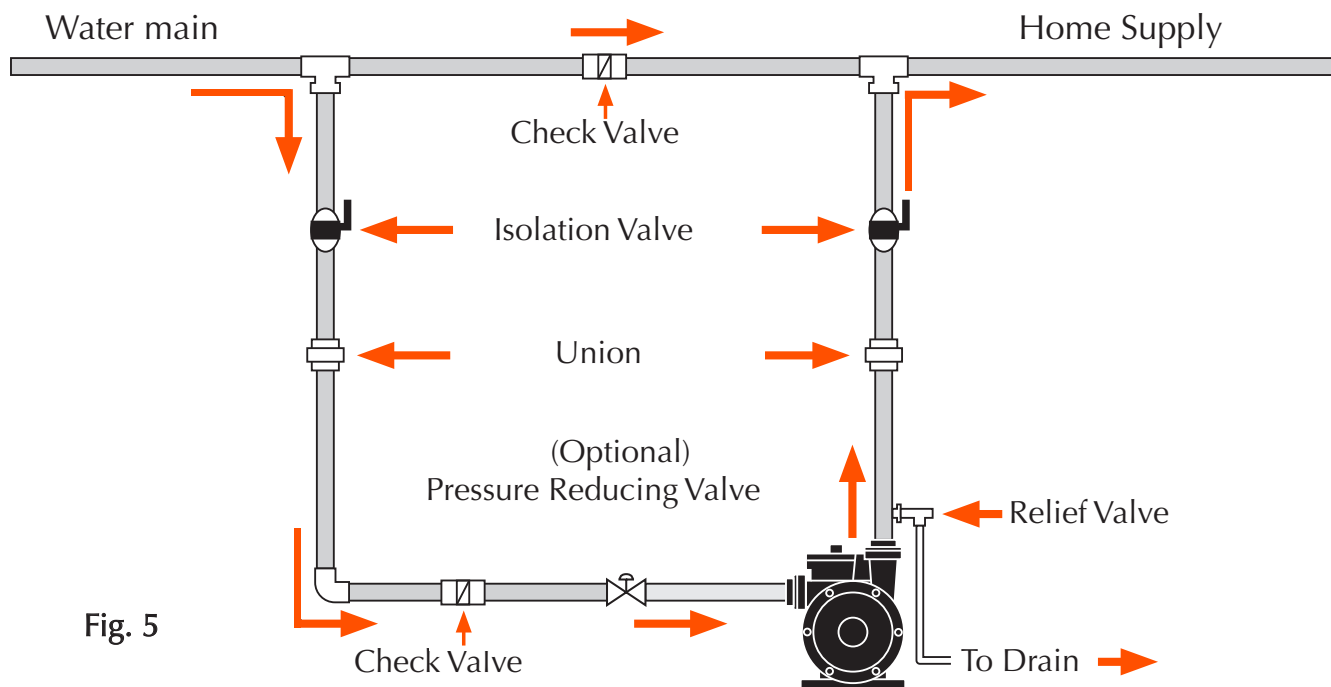

Fig. 5

Directly applied city pressure can exceed pump operating pressure and damage the pump.

The maximum inlet pressure should not exceed 45 PSI. Any greater incoming pressure is required to install a pressure reducing valve on the suction side of the pump. In some areas where local codes restrict maximum home pressure, a pressure reducing valve is also required on suction to lower the inlet pressure.

The chart below shows the applicable settings for the pressure reducing valve:

3. SUCTION LIFT- BELOW GROUND WATER SOURCES

This connection does not require any adjustment. Whenever the installation position of the pump is higher than 3ft above the lowest water level, a foot valve must be installed on the end of suction pipe.

WARNING

The pump is not designed for continuous operation under low discharge flows such as slow closing float valves, slow running taps. Under this application, please install an extra tank (typically 2-3 gallon) to avoid "cycling". (Fig 6)

Please set the extra pressure tank prussure the same as activation pressure. Leaking discharge line and leaking taps will damage the unit through causing the pump to repeatedly start and stop.

Note: Optional external water pressure tank can be used to decrease the on/off cycle rate of the pump system, which can extend the life of the pump.

Fig. 6

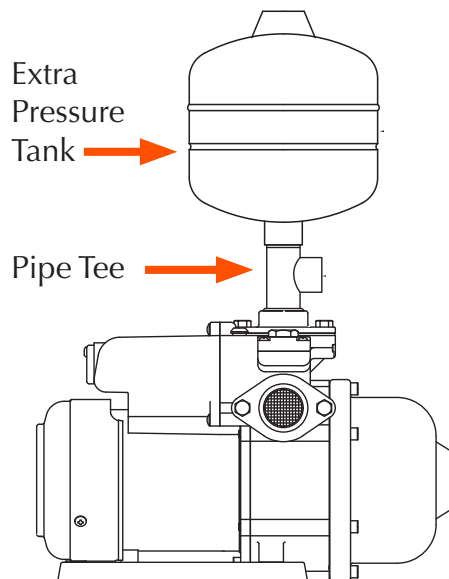

ELECTRICAL



This mark located outside the connection box is a warning for an electrical hazard.

1. Ensure the mains voltage is the same as the value shown on the motor plate and that the pump is safely connected to ground/earth.
2. The single phase models are supplied with plug and lead and can be connected directly to the mains supply. The 3 phase models should hook up with a circuit breaker.

WARNING

Risk of electric shock - This pump has not been investigated for use in swimming pool or marine areas.

- To reduce the risk of electric shock, connect only to a properly grounded, grounding-type receptacle.
- Before operation, please ensure the voltage is correct and the circuit breaker and grounding
- connectors are all connected in accordance with local regulations.

Part #	Plumbing In / Out	Voltage	Amps	Flow Rate	High Pressure Cutoff	Duty Cycle
DDP-60	1 1/2" NPT	240VAC	9.5A	60 GPM	Yes	Constant

STARTING

Before starting, the pump must be primed. For installation with no inlet pressure, please follow the procedure as shown in Fig. 8.

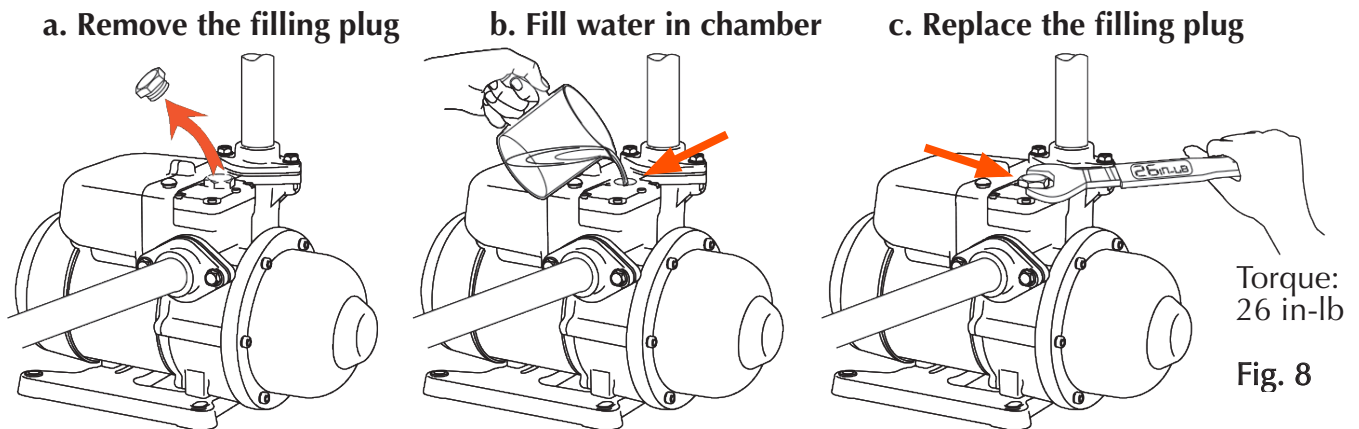

1. For installation with inlet pressure, remove the priming plug and allow the water to flow into the priming chamber until all air is expelled.
2. The priming procedure should be repeated until all air is expelled and the pump delivers a full stream of water without bubbles.
3. The pump must always be checked for prime if not used for a prolonged period. It is imperative to fill the pump with liquid before operation as dry running causes irreparable damage to the mechanical seal.
4. When a 3-phase motor is supplied, please ensure if the rotation is correct. You can switch any of the 2 wires to change the rotation.

INSTRUCTIONS CONT.

PRECAUTIONS

1. The pump should be shut-down and the trouble corrected if the pump is running at speed and found to have any of the following problems:
 - No liquid discharged - Not enough liquid discharged
 - Excessive vibration - Motor runs hot
2. Do not allow the pump to continually start and stop (cycling) as this will reduce the motor life.
3. Cycling can occur on pressure units when the pressure tank pre-charge drops, or where there is a leak in the discharge plumbing.

OPERATION & MAINTENANCE

Under normal operating conditions, the pump does not require any maintenance as long as the following points are observed.

1. Periodically check the condition of the check valve and strainer (if used).
2. If the pump is to be inactive for long periods, it should be rinsed thoroughly with clean water, then, drained and stored in a dry place. (It has to be pre-primed before start-up).
3. If the pump shaft is seized up after periods of inactivity, please place a screw driver from the motor end to rotate the shaft. It should free the pump shaft. (See Fig. 9) If this does not remedy the problem, the unit will need dismantling.

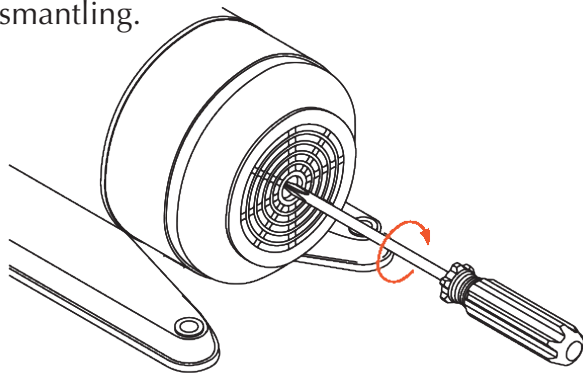

Fig. 9

4. Pressure Tank air charge should be checked at regular intervals of every 6 months and after the pump has not been used for a prolonged period. To check the Pressure Tank air pressure, turn off the power, open a tap on the discharge line to release pressure from the pump, unscrew the black plastic cover and apply an accurate pressure gauge to the valve as shown in Fig. 10. Pressure should be adjusted to the original pre-charge as follows:

- DDP-60: 20psi (1.4 Kg/cm²)

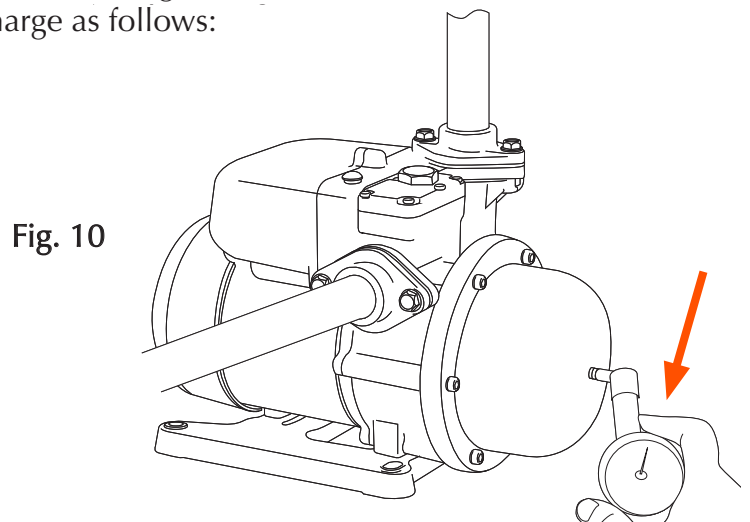

Fig. 10

FREQUENTLY ASKED QUESTIONS

1. WHAT CAUSES THE DDP-60 TO START?

The DDP-60 has the built-in pressure switch and internal flow switch. Each of these can turn the pump on depending on water consumption.

The pump will start when:

- The pressure is BELOW the pressure switch activation point. OR
- The flow rate is greater than 0.7 GPM.

2. WHAT CAUSES THE DDP-60 TO STOP?

The flow switch is designed to automatically stop the DDP-60 when flow drops to below 0.7 GPM. The DDP-60 is programmed to stop after 8 seconds. In addition, the DDP-60 will be turned off in the event of dry-run or over temperature alarm.

3. WHAT IS THE PURPOSE OF THE BUILT-IN PRESSURE TANK?

The pressure tank comes from the factory pressurized at approximately 20 psi (with the pump pressure at zero). It is designed to minimize motor startup due to small flow demand or minor leak of the pipeline.

4. HOW IS THE DRY-RUN CONDITION DETERMINED AND THE PROTECTION PROVIDED?

The dry-run is defined when the motor is running AND the flow rate is less than 0.3 GPM AND when pressure is less than the pressure switch setting.

The protection is provided:

- When the pump is run dry 2 minutes, it will automatically shut off for 10 minutes and then attempts to restart. When all 3 attempts are failed, the pump will rest for 1 hour and then attempts to restart. This protection mode will be repeated until the water supply is back to normal.
- In case the pump is cycling (on-and-off repeatedly) due to small flow (less than 0.3GPM), air pocket in the system, air loss in the pressure tank or leak in the pipeline, the protection is provided:
- The pump will run for 8 seconds and stop for about 3 seconds. When the cycling mode repeats for 15 times consecutively, the pump will rest for 1 hour. Then it will start over the protection mode until the problem is corrected.

Note: The pump can be reset anytime by removing the power plug.

5. WHAT IS THE MAXIMUM INLET PRESSURE ALLOWED IN THE DDP-20?

The maximum internal system pressure allowed for DDP-60 is 120 psi.

The maximum inlet pressure when added to the DDP-60 pressure must not exceed 120 psi.

For example with a 40 psi inlet pressure supplied to the pump, internal system pressures can reach approximately 107 psi (67 + 40 psi). Additionally, if inlet pressures exceed the built-in pressure switch activation point (20 psi factory default), the pressure switch will be unable to function, and the ability to turn the DDP-60 on at low flow rates will be lost. In this situation, only the flow switch will be able to turn the DDP-60 on at flow rates above 0.7 gpm.

SPECIFICATIONS

DIMENSIONS (INCHES)

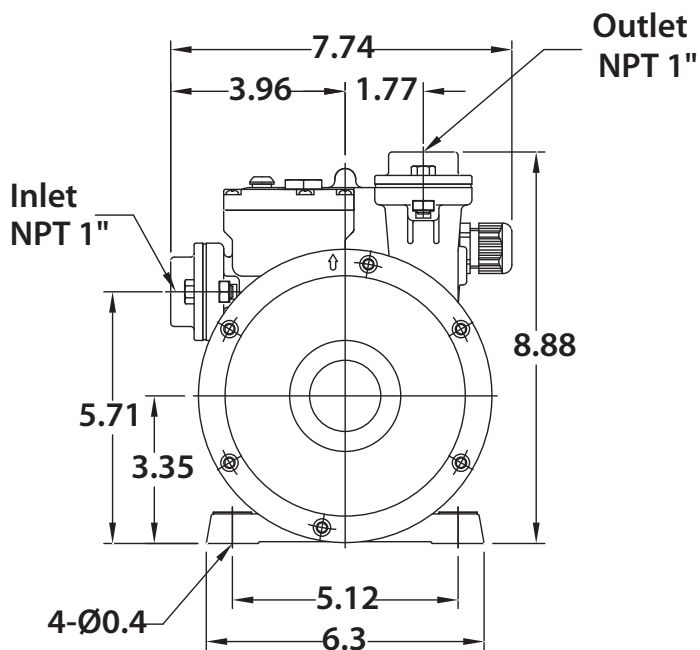
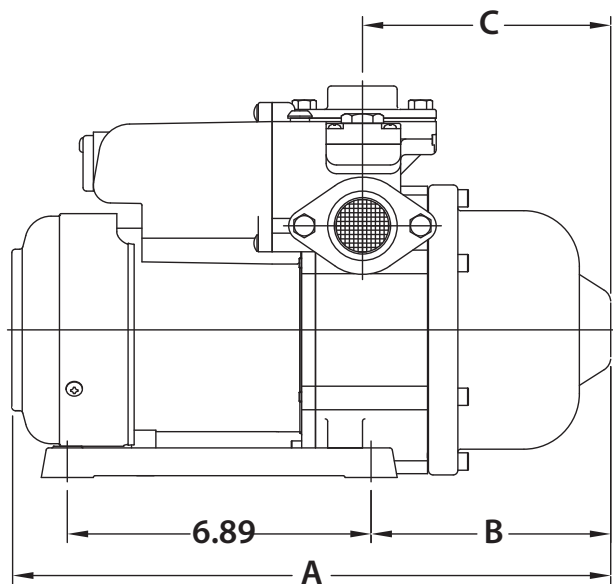

DDP-60: (A)13.23" (B) 5.08" (C) 5.28"

GROWONIX SYSTEM WARRANTY

For a period of one year from the date of original purchase, we will replace or repair any part of the GrowoniX product that we find to be defective in operation due to faulty materials or workmanship with the exception of the replaceable filters and membranes.

GENERAL CONDITIONS

Damage to any part of this product because of misuse; misapplication; negligence; alteration; accident; installation; or operation contrary to our instructions, incompatibility with accessories not installed by GrowoniX, or damage caused by freezing, flood, fire, or Act of God, is not covered by this warranty. In all such cases, regular charges will apply. This limited warranty does not include service to diagnose a claimed malfunction in this unit. This warranty is void if the claimer is not the original purchaser of the unit or if the unit is not operated under normal municipal water or well water conditions.

GrowoniX assumes no liability in connection with this product. GrowoniX assumes no liability for any damages incurred through the use of this product. It is the responsibility of the end user to gauge the safe use of this product in the environment where it is applied. We do not authorize any person or representative to assume for us any other obligations on the sale of this reverse osmosis system. The information given out in the manual we believe to be true, but are offered to you in good faith without guarantee because each application of this product is different and beyond our control.

GROWONIX RETURN POLICY

MERCHANDISE RETURN DETAILS AND PROCEDURE:

If any merchandise was defective —we will refund the full purchase price upon receiving and reviewing the merchandise returned in undamaged condition.

RMA NUMBER:

You must first obtain a Return Merchandise Authorization (RMA) number from GrowoniX.com. Any products sent to GrowoniX without an RMA number will not receive a refund and may be returned to the sender at their expense. All refund amounts will be based on the manufacturer's warranty and GrowoniX return policy. Refunds will be issued back using the payment method you used when you placed your order. Refunds take up to 3-5 business days to process once we receive the return.

PACKAGING:

Please kindly re-pack the product in its original box, or a box of equivalent strength. The unit should be packed in the same manner as it came to prevent damage in shipping. Please return everything that was in the original box, including any free items if applicable. Be sure to drain out all water from wet systems and parts and wrap them in plastic bags before packing.

RETURN TO:

We will provide you with an GrowoniX warehouse address for return merchandise when we issue the RMA number.

GROWONIX

TUNED FOR GROWING



DDP-60

ELECTRONICALLY
CONTROLLED PUMP

INSTRUCTION MANUAL

WWW.GROWONIX.COM

GROWONIX
TUNED FOR GROWING



Built in the U.S.A.